

Industrial double gas detector Methane & CO



CHCOind

The industrial gas leak detector **CHCOind** has been designed and built according to European regulations to detect the presence of **toxic and explosive** gas.

A microprocessor is used to create a complete surveillance and control system with maximum flexibility. Thanks to this and its other features, this detector is suitable for industrial applications.

CHCOind can **detect the presence of two gases**.

The first gas detected is **methane-propane** with trip sensitivity calibrated at 10% of L.E.L.

The second gas detected is **carbon monoxide**, when both the maximum CO admissible concentration threshold of 300ppm is exceeded, and when low CO concentrations persist in the environment for lengthy periods, which according to the principle of accumulation could also damage the human organism.

The detector can activate solenoid valves, sirens, and any other signal or alarm handling devices using built-in relays. A series of technical features make this detector extremely versatile, reliable, accurate, and safe

The relay, free of voltage, allows installation of multiple detectors on a single solenoid valve ensuring control of multiple dangerous environments.

The detector is complete with a special circuit that controls the sensor's efficiency level, and signals any possible fault.



Important: Assembly / maintenance of the appliance must be carried out by qualified personnel and in accordance with applicable laws and regulations.

The manufacturer assumes no responsibility for the use of products that have to comply with particular environmental and / or installation standards.



This equipment is designed to protect individuals from acute exposure to carbon monoxide.

This equipment will not completely protect the Individuals with specific medical conditions.



In doubt, consult a doctor.



Important note

Before connecting the equipment, it is recommended that you read the instruction manual carefully and keep it for future reference. It is also recommended to perform the electrical connections correctly as per enclosed drawings, observing the instructions and the Standards.

N.B. Refer to the documentation in all cases where the symbol is on the side

 <p>Installation and user guide</p>	<p>CONFORMITY</p>  <p>EN 50194 EN 50291 EN 50270 CEI 216-3 Installation EN 60079-29-2</p>
---	---



Precautions

CHECK the integrity of the unit after having removed it from the box.

Check that the data written on the box correspond to the type of gas used.

When doing the electrical connections, follow the drawing closely.

Any use of the detector for purposes other than the intended one is considered improper, and as a result of which **BEINAT S.r.l.** therefore disclaims any responsibility for possible damages caused to people, animals or objects.

IMPORTANT: Do not test the device using the gas tap as this does not necessarily provide sufficient concentration to activate the main alarm.

TERMS and EXPECTATIONS: The installation of **CHCOind**, its ordinary and extraordinary maintenance, Once a year, and its out of service removal at the end of the functional life guaranteed by the manufacturer, must be carried out by authorized or specialized personnel.

In order to achieve long and satisfactory use of your gas detector,, use it by respecting the following precautions.

Do not drop it.

Heavy knocks or falls during transportation or installation can damage the appliance.

Avoid abrupt temperature fluctuations.

Sudden temperature variations can cause condensation and the detector could work poorly.

Do not allow it to become wet.

The control unit can be seriously damaged as it is not waterproof either when immersed in water or exposed to high levels of humidity.

Cleaning

Never clean the device with chemical products. If necessary, wash with a moist cloth.

MAINTENANCE



The user periodically (every 6 months) must perform a check of the operation of the control unit by spraying a suitable test gas at the base of the probes connected until the alarm condition is reached.

- At least once a year make a more accurate check by a specialist technician.
- Disabling the detector must be carried out by qualified personnel.

Technical Specifications

Power supply **230Vac 50 /60 Hz +/- 10%**
Power consumption 1W
Change-over relays **for explosive gas** detection 10A 250V ~ resistive
Change-over relays **for CO toxic** gas detection 10A 250V ~ resistive

Explosive Gas

Explosive gas sensor Catalytic
Explosive gas alarm threshold At 10% of L.E.L

Toxic Gas

CO toxic gas sensor **Electrochemical Cell**
CO detector alarm sensitivity 30 ÷300ppm after 2h

Audible and visual signal alarm by LED diode and buzzer

Sensors' faults detected by Fault Circuit Interruption, short circuit, or wear

Functioning Temperature -10°C to +50°C

Functioning Humidity 0÷90% RH non condensed

Accuracy 1% f.e.

Control unit.....10-bit microprocessor

Start time 90 seconds

Manual test built-in

Protection degree IP65

Mounting Wall

Body material ABS self-extinguishing

Dimensions 155x120x75 mm

Electromagnetic Compatibility EN50270

Components and commands

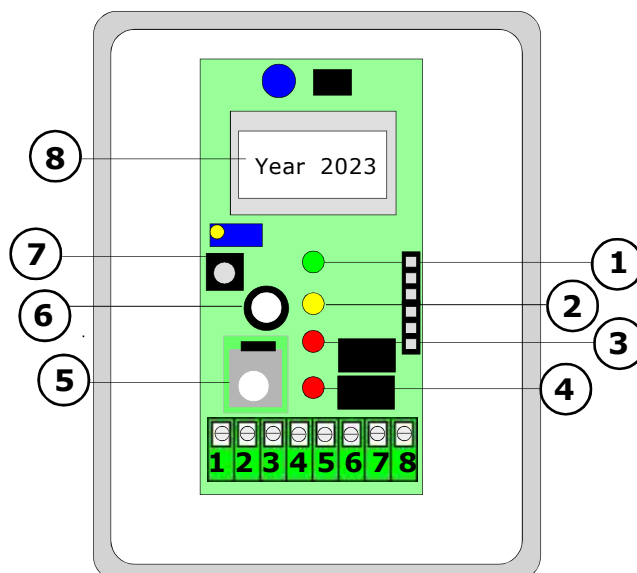

1) MAINS connected indication LED. When the unit turns on, this LED blinks and a test of the gas detection sensors' efficiency status is carried out. This phase takes about 100 seconds. Afterwards the LED stays on without blinking. **During the test period, CHCOind does not detect the gas.**

2) FAULT indication LED. If this LED turns on, it means that one of the gas detection sensors is not working efficiently and must be replaced in an authorized centre. An acoustic signal is connected to the fault circuit, with a frequency of 10 minutes.

A relay is connected to the fault circuit as well as the light indication and a "cricket" siren.

3) Explosive GAS ALARM indication LED. This LED lights up and blinks when the gas concentration level has reached 10 % of LEL. The relay contact is closed, and an intermittent sound is issued.

4) CO ALARM indication LED. This LED lights up when the gas concentration level has reached the 300ppm concentration, or when the accumulation level is reached. The relay contact is closed, and an impulsive sound is issued.

5) Electrochemical Cell sensor for Carbon Monoxide detection

6) Catalytic sensor for explosive gas, methane and LPG detection.

7) TEST button. This button is used to simulate a gas leak, after installation.

8) Identification label, serial number and manufacturing year.

9) Label of the gas sensor expiration date.

This label must be applied by the technician during the installation and remembering that the gas sensor **must be reviewed after 5 Years.**

Dimensions

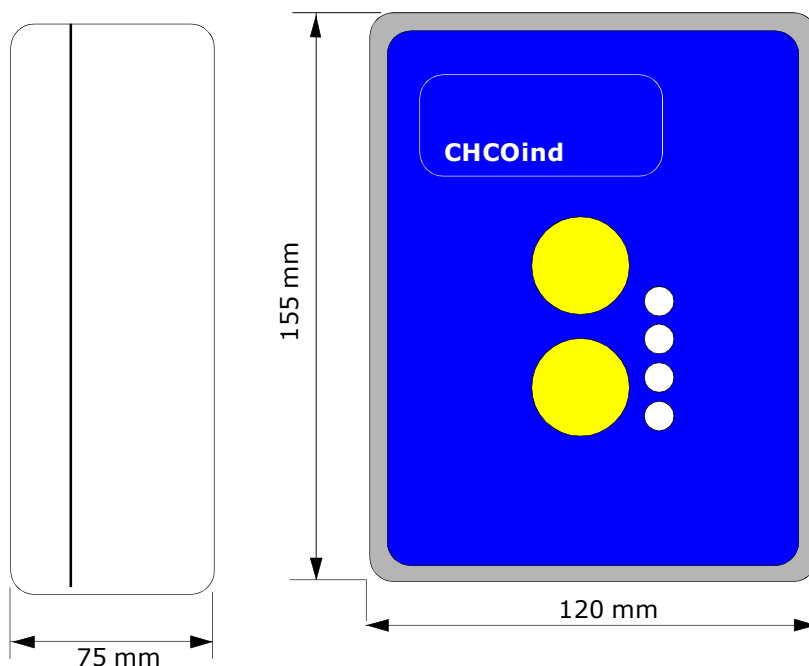

Electrical connections



WARNING.

Before connecting to the mains power, ensure the voltage is correct. Carefully follow the instructions and the connections according to Regulations in force, keeping in mind that **the signal cables should be laid separate from the power cables.** An automatic cut-off switch (appropriately identified as device sectioning of the detector) should be incorporated in the electrical system, adequately located and easily accessible.

Connection Scheme of the Detector

ATTENTION !

The relays are voltage free

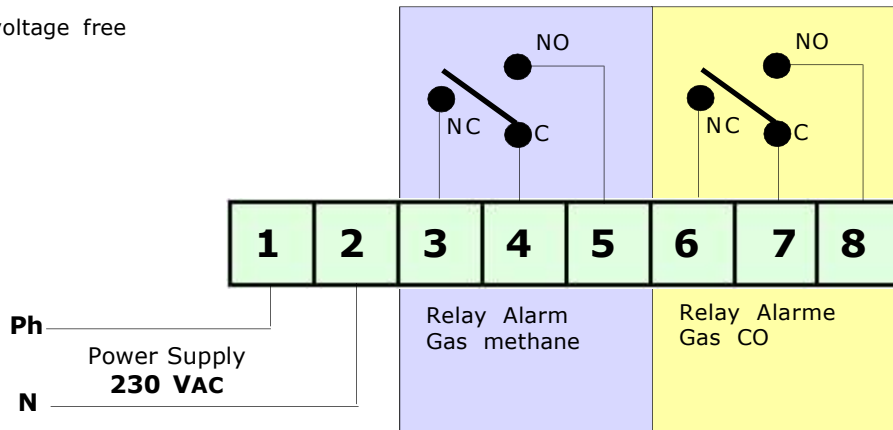

Connection Scheme normally close valve 230VAC

ATTENTION !

The relays are voltage free

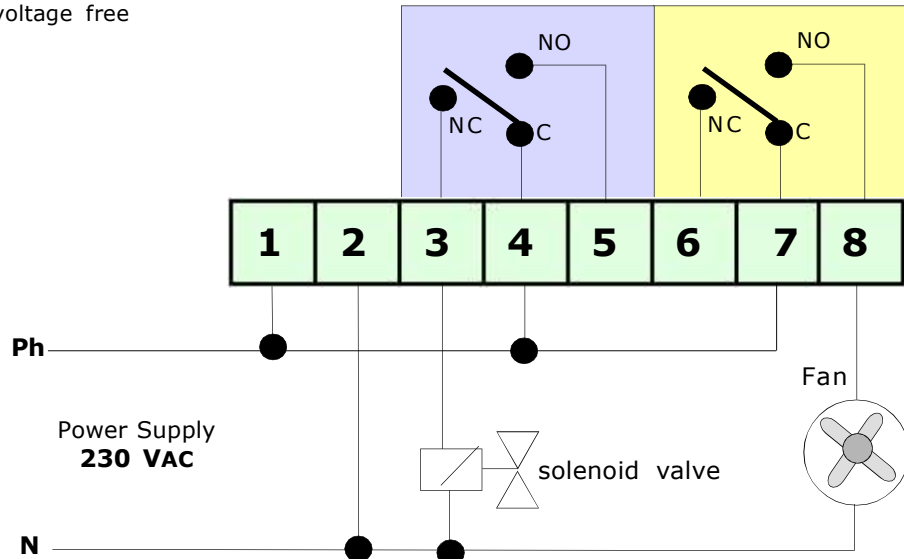

Connection Scheme normally open valve 230VAC

ATTENTION !
The relays are voltage free

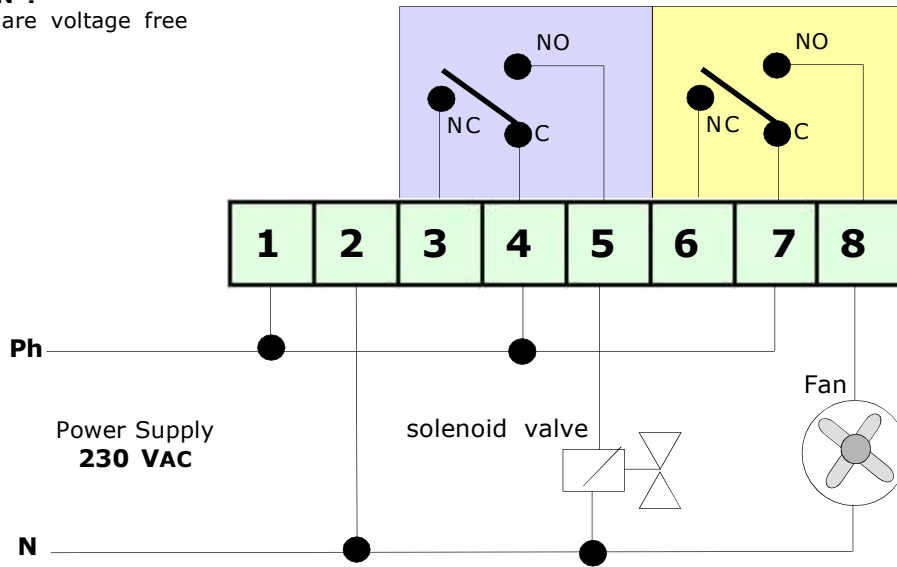

One or more detectors with a normally open valve 230VAC

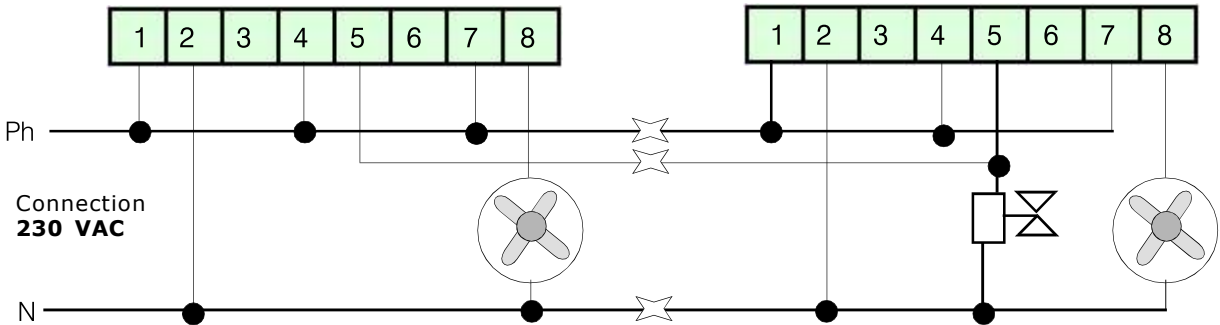

One or more detectors with a normally close valve 230VAC

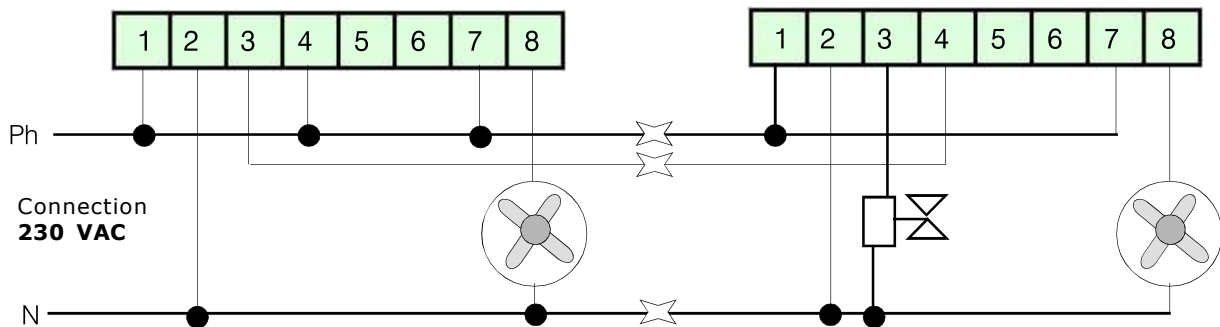

ATTENTION !
The relays are voltage free

Installation measures and positioning

The position of the detector is a crucial factor for its correct functioning during gas detection.

In order to obtain the maximum results from a device and minimize the probability of false alarms, it is recommended to follow this scheme and keep in mind the following general regulations.
The **CHCOind** is an equipment adapted to be mounted on a wall.

When installing is good to use reasonable care that requires an electronic device, and then:

- Install the detector away from sources of heat.
- Avoid that the liquids may come into contact with the detector, remembering that its box has a degree of protection IP65.

The detector **must not be installed** behind the barriers that hinder the prompt detection of gas . near of aspirators or fans and in areas where the temperature falls below 10 ° C or rises above 40 ° C.

The installation height of the detector **CHCOind** must be from a minimum to a maximum of
Maximum 30 cm from the highest point of the ceiling
Minimo 160 cm. from the floor

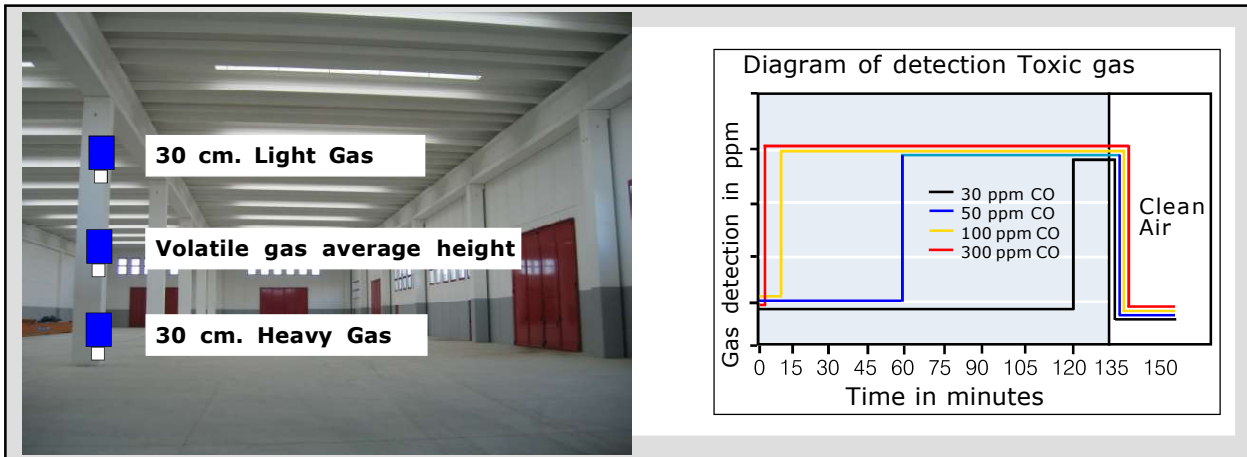

Turn on and testing

When powering on **CHCOind**, you will see that the MAINS LED lights up and starts blinking for about 90 seconds. Afterward the LED stays on without blinking, **CHCOind** is ready to detect.
Press the **button** placed on the side the sensor to simulate the presence of gas.
The **Led alarm** lights up, the relay changes the state of work after 5 minutes.
Ceased the alarm, the Led turns off, it stops the sound of the buzzer and the connected devices will be disab

Test run with GAS

To test the explosive gas emit the gas from a pre-calibrated bottle within 10% of the LEL inside the sensor concerned. This test is recommended to be performed once a year. Do a test with a common cigarette lighter could damage the sensor.

To test the toxic gas emit gas from a pre-calibrated bottle from 30 to 300 ppm, in the grey sensor. Using other types of gas could damage the sensor. This test is recommended to be performed once a year.

Before calling a technician check ...

If the device does not start up.

Check that the 230V power is correctly connected.

If the fault LED yellow lights up.

Check the **CHCOind** detection capsule status. They may faulty or to have exhausted after 5/6 years must be replaced.

If the detector is repeatedly issuing an alarm..

1) Check that there are no gas leaks.

2) Check that there is not a persistent low concentration of CO, Check! see table on page 4

Make sure that together with the alarm it does not turn on even the FAULT led., in this case proceed to the control of the sensors.

If the detector is issuing an alarm and does not shut off the devices connected to it.

Check that the wiring is correct and that the jumper that carries power to the relay has been set properly

We advise that **all relays are tension free.**

Check the drawing of the connections.

If the CHCOind is connected to a solenoid valve 12VDC and is not operate

The **CHCOind** can not be connected directly to solenoid valves, sirens to 12 VDC

Si deve sempre ricorrere ad una alimentazione esterna.

Do not tamper the detector.

Not to cause the decalibration of the device, and electric shock.

If other problems arise, a specialised and/or authorised technician and/or the **Distributor of BEINAT S.r.l.** should be contacted directly.

Operating specifications of the gas sensors

The ELECTROCHEMICAL CELL technology sensor has a duration of: 5 years.

The CATALYTIC technology sensor has a duration that can vary: from 5 to 6 years.

T

ATTENTION!

The CATALYTIC sensor does not tolerate a gas detection exceeding **100% of L.E.L.**, with consequent natural death of the sensor.

Each immediate puff of gas that exceeds **100% of L.E.L.** takes away months of life from the sensor.

To test the toxic gas, issue gas from a pre-calibrated aerosol from 30 to 300 ppm.

The detector must be tested by simulating the presence of gas issuing it from a pre-calibrated aerosol.

WARNING! Actions to be taken in case of alarm

1) Put out all free flames.

2) Close the main gas tap or the LPG cylinder tap.

3) Do not turn any lights on or off; do not turn on any electrical device or appliance.

4) Open windows and doors in order to increase ventilation.

If the alarm stops, its cause must be found and the relevant consequent measures taken.

If the alarm continues and the cause of gas presence cannot be found or removed, abandon the building and call the emergency services when outside (fire department, distributors, etc.)

The installation of the detector does not exempt..... from the compliance with all regulations concerning the characteristics, installation and use of gas appliances, the ventilation of the spaces and the elimination of combustion products are described in the **UNI norms according to ART. 3 LAW 1083 / 71** and relevant legal provisions.

INSURANCE. This device is insured by the SOCIETÀ REALE MUTUA for the PRODUCT'S GENERAL LIABILITY up to a maximum of 1,500,000.00 EURO against damages caused by the device in case of failures in functioning.

WARRANTY. The warranty term is 3 years from manufacturing date, in agreement with the following conditions. The components acknowledged as faulty will be replaced free of charge, excluding the replacement of plastic or aluminium cases, bags, packing, batteries and technical reports.

The device must arrive free of shipment charges to **BEINAT S.r.l.**

Defects caused by unauthorized personnel tampering, incorrect installation and negligence resulting from phenomena outside normal functioning shall be excluded from the warranty.

BEINAT S.r.l. is not liable for possible damage, direct or indirect, to people, animals, or things; from product faults and from its enforced suspension of use.



DISPOSAL OF OLD ELECTRICAL & ELECTRONIC EQUIPMENT.

This symbol on the product or its packaging to indicates that this product shall not be treated as household waste. Instead, it shall be handed over to the applicable collection point for the recycling of electrical and electronic equipment, such as for example:

- sales points, in case you buy a new and similar product
- local collection points (waste collection center, local recycling center, etc...).

By ensuring this product is disposed of correctly, you will help prevent potential negative consequence for the environment and human health, which could otherwise be caused by inappropriate waste handling of this product. The recycling of materials will help to conserve natural resources. For more detailed information about recycling of this product, please contact your local city office, your household waste disposal service or the shop where you purchased the product.

Attention: in some countries of the European Union, the product is not included in the field of application of the National Law that applies the European Directive 2002/96/EC and therefore these countries have no obligation to carry out a separate collection at the "end of life" of the product.

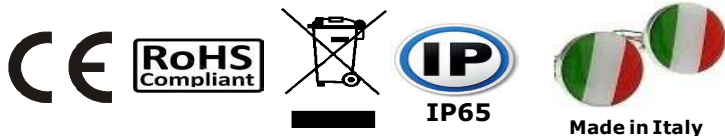

Detector CHCOind *Lo styling è della b & b design*

Dealer Stamp

Purchase Date:.....

Registration Number :.....

Beinat S.r.l. following the targhet to improve its products, reserves the right to modify the technical features, aesthetic and functional any time **without prior notice.**

BEINAT S.r.l.
Via Fatebenefratelli 122/C 10077, S. Maurizio C/se (TO) - ITALY
Tel. 011.921.04.84 - Fax 011.921.14.77
[http:// www.beinat.com](http://www.beinat.com)

 **Business** - info@beinat.com
Help Desk - laboratorio@beinat.com