

# R290 Addressable refrigerant gas sensor

## SGI621

rev. 1

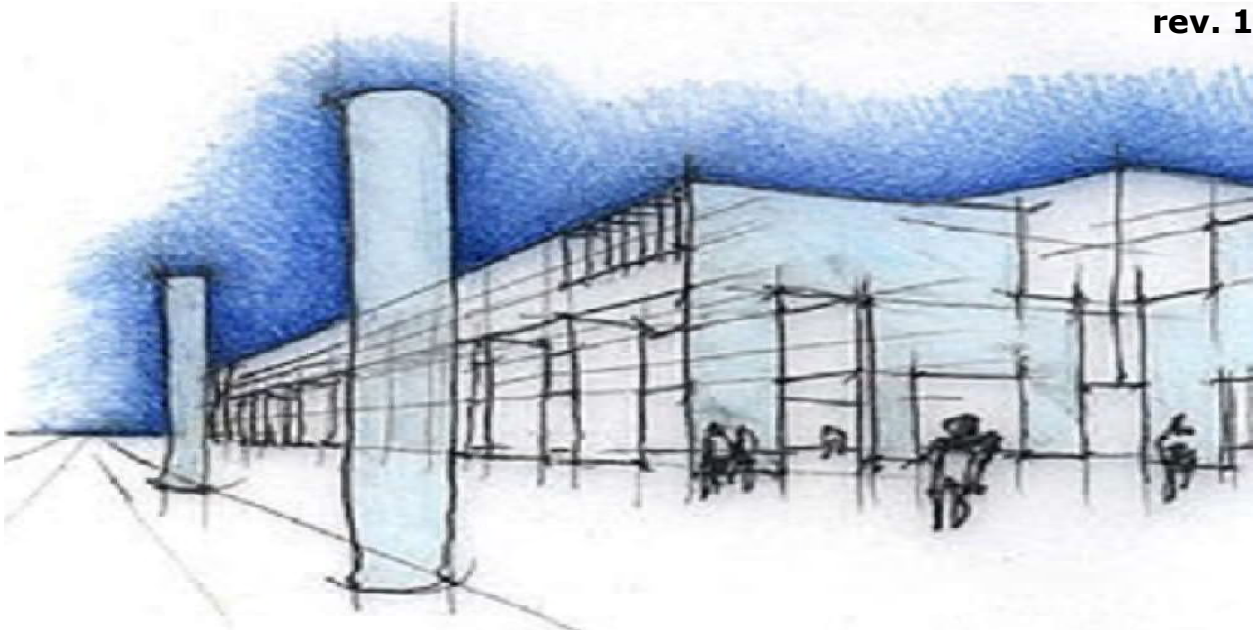

The years of experience gained in the industrial sector and the knowledge of the market combined with the prestige that has always distinguished **BEINAT S.r.l.**, and the industrial fitness concept have allowed the conception of the gas sensor **SGI621**. It has the prerogative to control the presence of explosive gases, via a **RS-485 MODBUS** network through the catalytic technology sensors, so it can be combined with our **BXI32** control unit.

Thanks to more innovative technical features such as control software, the probe is suitable for: industrial and civil use detecting the **freon R290**.

The sensor is managed by a microprocessor which, in addition to supplying an alarm signal to the control unit to which it is connected, allows self-diagnosis, and therefore an **AUTOMATIC CALIBRATION**, in order to have the highest detection accuracy over time.

The automatic calibration allows the probe to adapt in difficult and variable temperature environments, avoiding false alarms due to anomalous events.

The important novelty of this probe is the possibility of replacing the sensor at the end of the operating cycle or due to a failure by the technician without having to send it to **BEINAT S.r.l.**

### Indispensable instrument for the annual check of the probes

#### Instrument of testing TS1008

To facilitate the reading of the functional parameters of the probe as well as the control of annual operating, the **BEINAT S.r.l.** has built a new portable tester **TS1008**.

The tester allows to read all the data in the memory of the probes and by serial transmission, it prints the ticket that confirms the testing data, **certifying your own work...**



**Important:** Assembly / maintenance of the appliance must be carried out by qualified personnel and in accordance with applicable laws and regulations. The manufacturer assumes no responsibility for the use of products that have to comply with particular environmental and / or installation standards.



#### Important note

Before connecting the equipment, it is recommended that you read the instruction manual carefully and keep it for future reference. It is also recommended to perform the electrical connections correctly as per enclosed drawings, observing the instructions and the Standards.

**N.B. Refer to the documentation in all cases where the symbol is on the side**



**Installation and user  
guide**

#### CONFORMITY

**EN 50194  
EN 50270  
Compliant EN 60079-29-1  
Installation EN 60079-29-2  
Reports issued by TUV Italia**

## Precautions

**CHECK** the integrity of the unit after having removed it from the box. Check that the data written on the box correspond to the type of gas used. When doing the electrical connections, follow the drawing closely. Any use of the detector for purposes other than the intended one is considered improper, and as a result of which **BEINAT S.r.l.** therefore disclaims any responsibility for possible damages caused to people, animals or objects.

**TERMS and EXPECTATIONS:** The installation of the **SGI621** Sensor, its ordinary and extraordinary maintenance, every six months, and its out of service removal at the end of the functional life guaranteed by the manufacturer, must be carried out by **authorized or specialized personnel**.

**Do not allow it to become wet.**

The control unit can be seriously damaged as it is not waterproof either when immersed in water or exposed to high levels of humidity.

**Do not drop it.**

Heavy knocks or falls during transportation or installation can damage the appliance.

**Avoid abrupt temperature fluctuations.**

Sudden temperature variations can cause condensation and the control unit could work poorly.

**Cleaning**

Never clean the device with chemical products. If necessary, wash with a moist cloth.



### MAINTENANCE



The user periodically (every 6 months) must perform a check of the operation of the control unit by spraying a suitable test gas at the base of the probes connected until the alarm condition is reached.

- At least once a year make a more accurate check by a specialist technician.
- Disabling the detector must be carried out by qualified personnel.



## Technical Specifications

Power Supply ..... **12÷24VDC** ± 10%  
Power demand ..... 90 mA in operating, 110 mA in alarm Max @ 13,8 V  
Rapports..... green light normal operation, yellow light fault, red light alarm  
Data transmission LEDs ..... **RX TX**

Detection ..... **freon R290**  
Sensor ..... Catalytic  
Sensitive element working range ..... 0 ÷ 100% of LEL  
Alarm Detection ..... 0 ÷ 20% of LEL  
Data transmission signal ..... Serial RS485 protocol **ModBUSRTU**  
**USB Test Socket** ..... **TS1008**

Detector accuracy ..... 1% FS  
Long term shift in clean air ..... < 3% of LEL  
Auto zero procedure ..... Included in the software algorithms  
Response Time ..... <10"  
Warm-up time ..... 1 minute

Functioning humidity ..... 0-90% non condensed  
Functioning temperature ..... -10°C to +50°C  
Control units usable ..... **BXI32**  
Maximum distance between sensors and control unit .....1000 m  
Cable diameter for connecting sensors .....0,50 mm<sup>2</sup>

Connection: **The cable of connection of the probe must not be installed together with the power cables. Otherwise, make sure to use a shielded cable**

Installation ..... Wall  
Probe's body material ..... ABS  
External degree of protection ..... **IP55**  
Size .....78x114x58 mm

## Technical Features SGI621

Code	Type of Gas	Sensor	Working range	Temperature
SGI621	R290	Catalytic	LEL 0-100%	-10+50°C

### WARNING!

The CATALYTIC sensor has a life span of 5 to 6 years *in clean air*.

The working temperature of the probe recommended is from -10 °C to + 50 °C.

Every puff of gas over 100% of L.I.E. Takes months off the sensor life.

Each immediate puff of gas that exceeds 100% of L.E.L. takes away months of life from the sensor.

The detector must be tested by simulating the presence of gas by issuing it from a pre-calibrated testing aerosol.

### Important:

The test of operation and eventually offset cancellation must be performed at least **once a year**, by a qualified technician.

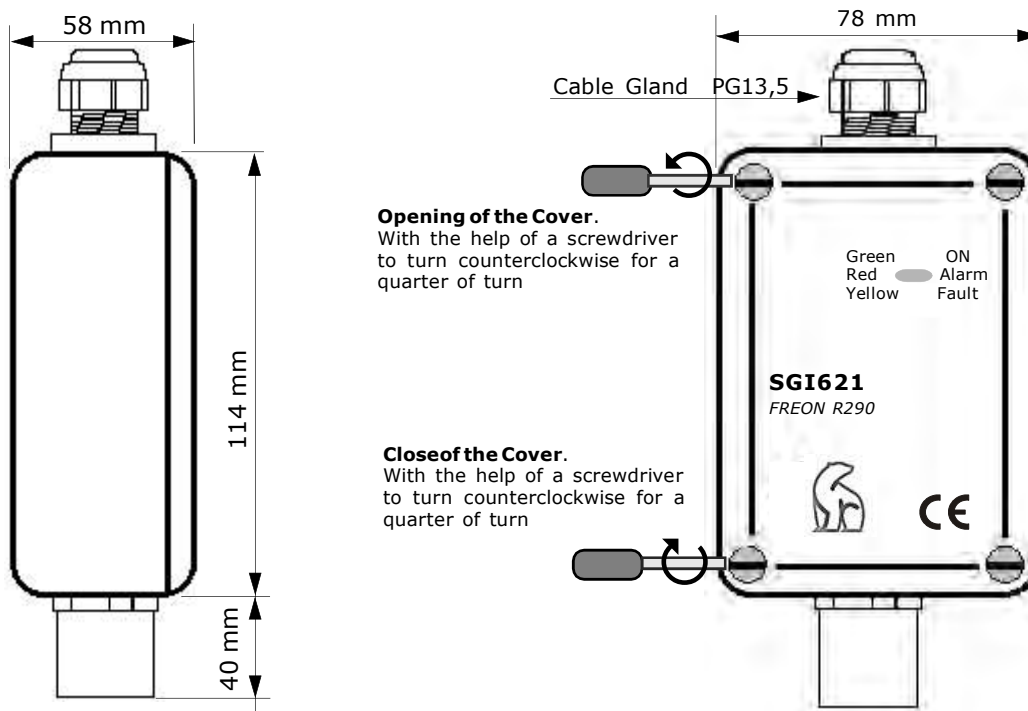

### FUNCTIONING OF LED



The integrated LED on the sonde has a threefold function:

- 1) Green LED. Normal operation; In waiting phase, the LED flashes.
- 2) Red LED. State of alarm; The frequency of light changes according to the percentage of gas monitored.
- 3) Led yellow. The probe detects an anomaly, FAULT

Yellow intermittent LED. Active communication

The installation of the detector does not exempt from the compliance with all regulations concerning the characteristics, installation and use of gas appliances. The ventilation of the spaces and the elimination of combustion products are described in the UNI norms according to ART. 3 LAW 1083 / 71 and relevant legal provisions.

# Electrical connections





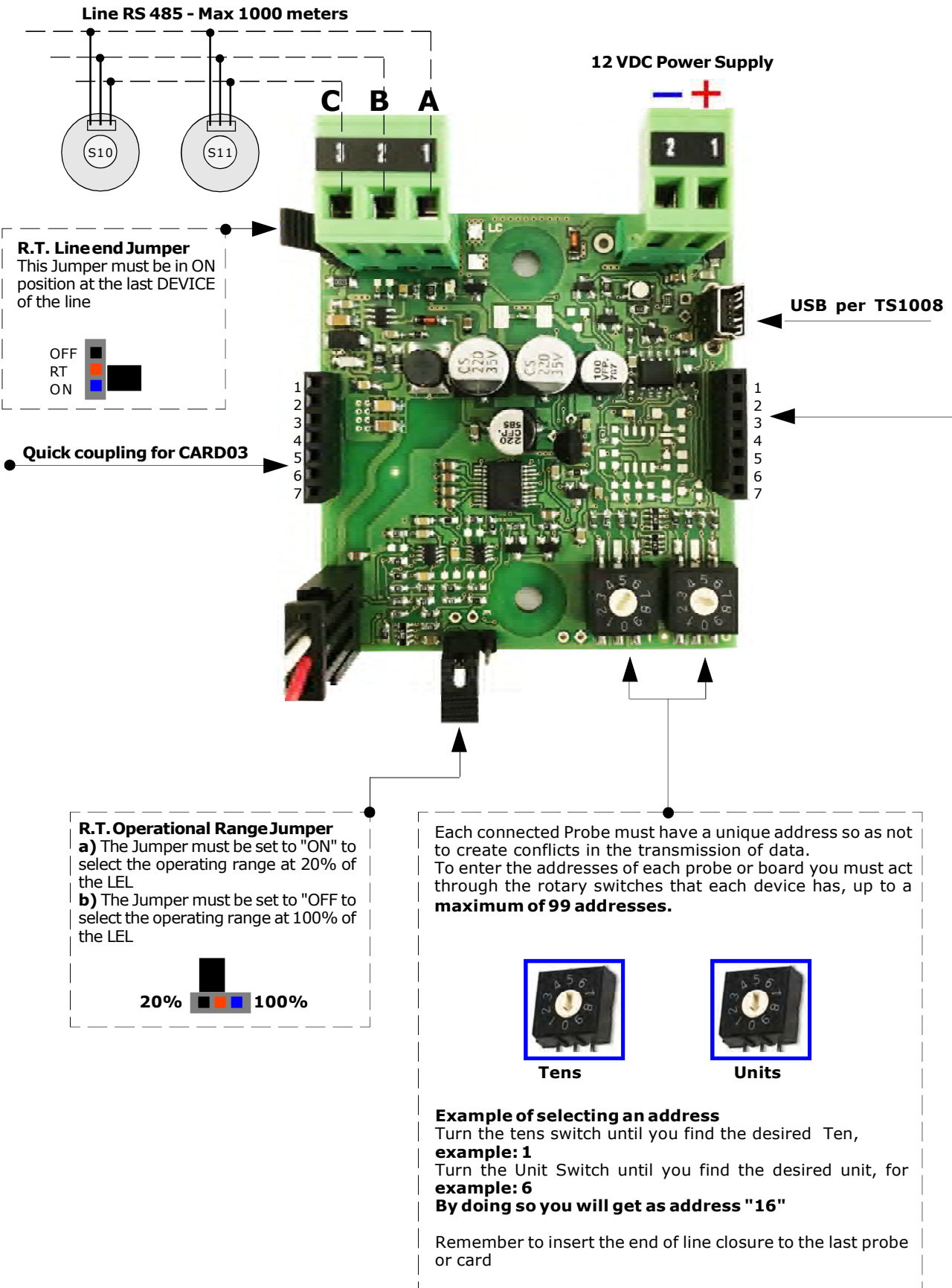

## WARNING

Before connecting to the mains power, ensure the voltage is correct. Carefully follow the instructions and the connections according to Regulations in force, keeping in mind that the signal cables should be laid separate from the power cables



**INSERTING THE CARD03 OPTIONAL CARD**



					
					
<b>1</b>	<b>2</b>	<b>3</b>	<b>4</b>	<b>5</b>	<b>6</b>
Fault		Pre-Alarm		Main Allarme	

Before inserting the Relé CARD03 board, disconnect the probe.  
 Insert the card inserting it as shown in the drawing, keeping the terminal board at the top right.

All the relays are free of tension. Contact capacity 1A 30VDC SELV

**CAUTION !!**

**RS485 BUS CONNECTION CABLES**

The bus connections must be made from a twisted and shielded pair with equivalent characteristics to **BELDEN type 9841 or BELDEN 9842** cables indicated in the table below:

Type	N° Pair	RESISTENZE IN DC		Nominal Impedence Ohm	NOMINAL CAPACITY		
		Wire Ohm/km	Shield Ohm/km		Between wires pF/m	AWG Shield pF/m	
<b>BELDEN 9841</b>	1	78,7	11,0	120	42,0	75,5	24 (0,25mmq)
<b>BELDEN 9842</b>	2	78,7	7,2	120	42,0	75,5	24 (0,25mmq)

- 1) The **total length** of the **RS485** network must not exceed **1000 meters**.
- 2) The minimum distance between two devices must not be less than 1 meter.
- 3) The branch line from the main network must not exceed 2 meters.
- 4) The shield of the BUS cable must be connected to earth at one end, for example on the peripheral near the control unit.
- 5) A second ground connection would not guarantee the equipotentiality of the screen.  
Do not use the same conduit for Bus and power supply cables, or power cables in general..

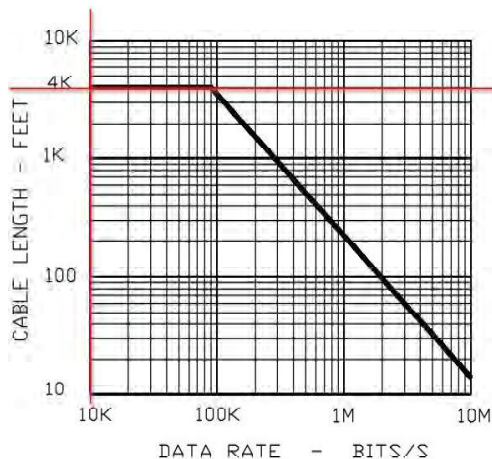



## Positioning of the Probe

The probes must be selected with an "IP" degree of protection depending on the area to be controlled (Kitchens, Boiler rooms, Laboratory, Factories, etc.) by choosing one of the probes produced by Beinat that goes from IP30 to ATEX.

The GAS sensors connected to this equipment are of various types and must be positioned at different heights depending on the type of gas to be detected.

These heights are:

- 30 cm. from the lowest point of the floor to detect heavy gases **R290**

**It is important to remember that the remote probes must be installed keeping in mind that:**

- 1) The probes must not be installed near the appliance to be controlled, boiler, burner, industrial kitchens, etc.) but on the opposite side.
- 2) The probes must not be affected by fumes, vapors, and by sources of moving air, which could distort the detection.
- 3) The probes must not be installed near sources of heat, fans or vacuum cleaners.

**NOTE.** Recall that the GAS detection sensors placed inside the probe are perishable components, whose average duration is variable from 5 to 6 years therefore after this period it is good to replace them.

### Maintenance

The user is kept periodically (every 6 months), to perform a verification of the operation of the detection system by spraying specific test gas to the connected probes, until the alarm status of the control unit is obtained.

- a) **Once a year**, a more thorough check must be carried out by a specialized technician.
- b) The removal of the probes after 5 years from installation must be carried out by qualified personnel.

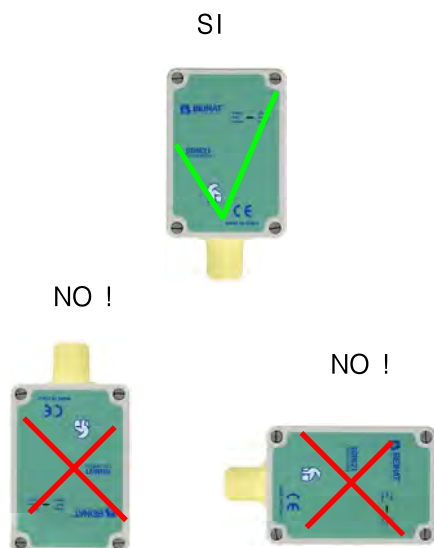

## Data detection diagrams

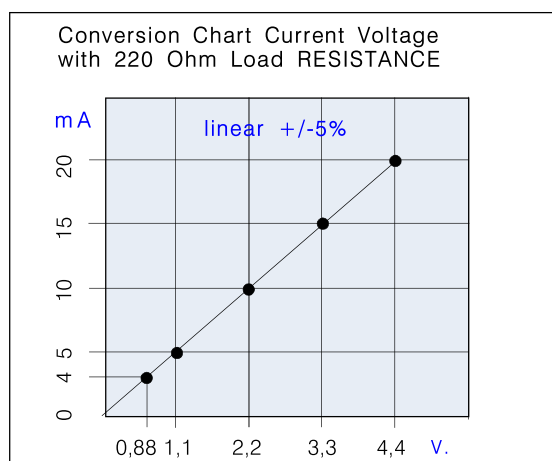
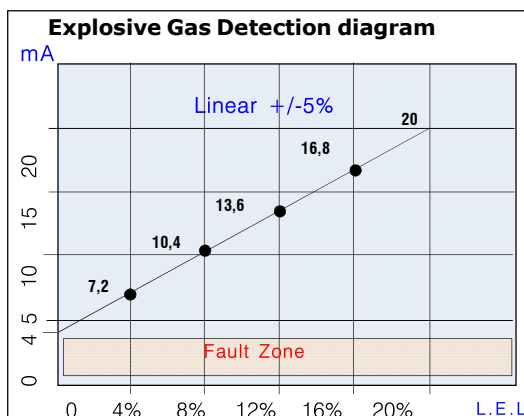

## Maintenance and gas sensor replacement

**Before performing this operation disconnect the power to the probe**



**Probe with sensor to be replaced**



**Probe with sensor removed**



**Sensor**



**Probe with sensor remounted**

**Test after replacing the sensor.**

Reconnect the power, the probe starts blinking to the waiting time (Warm-up). After waiting you can proceed to test the functioning inputting the sample gas.

**WARNING !!** From this moment on for all the duration of 24 hours of self-calibration, the probe must stay in clean air without loss of GAS.

The probe continues to blink at a low frequency again for 24 hours to make sure that the probe do the auto calibration.

## Gas input Test

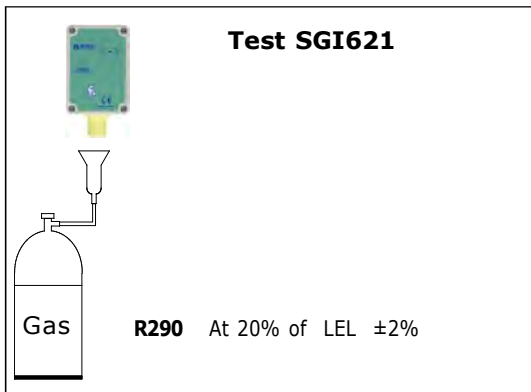

The installation of the sensor **SGI621**, its ordinary and extraordinary maintenance, and its out of service removal at the end of the functional life guaranteed by the manufacturer, must be carried out by authorized or specialized personnel.

The general test should be performed by issuing gas from a pre-calibrated aerosol within the percentages illustrated on the side.

**Important:** This test must be carried out at least once a year.

**WARNING!** Actions to be taken in case of alarm

- 1) Put out all free flames.
- 2) Close the main gas tap or the LPG cylinder tap.
- 3) Do not turn any lights on or off; do not turn on any electrical device or appliance.
- 4) Open windows and doors in order to increase ventilation.



If the alarm stops, its cause must be found and the relevant consequent measures taken.

If the alarm continues and the cause of gas presence cannot be found or removed, abandon the building and call the emergency services when outside (fire department, distributors, etc.)

**IMPORTANT:** The operation test should not be carried out with the gas tap as this does not guarantee a sufficient concentration to activate the general alarm.

**Warning !!**

If you have the following symptoms: vomiting, sleepiness, or else, go to the closest first aid station and inform the operators that you could have been poisoned by **Carbon Monoxide**, or by an excess or deficiency of oxygen



**INSURANCE.** This device is insured by the SOCIETÀ REALE MUTUA for the PRODUCT'S GENERAL LIABILITY up to a maximum of 1,500,000.00 EURO against damages caused by the device in case of failures in functioning.

**WARRANTY.** The warranty term is 3 years from manufacturing date, in agreement with the following conditions. The components acknowledged as faulty will be replaced free of charge, excluding the replacement of plastic or aluminium cases, bags, packing, batteries and technical reports.

The device must arrive free of shipment charges to **BEINAT S.r.l.**

Defects caused by unauthorized personnel tampering, incorrect installation and negligence resulting from phenomena outside normal functioning shall be excluded from the warranty.

**BEINAT S.r.l.** is not liable for possible damage, direct or indirect, to people, animals, or things; from product faults and from its enforced suspension of use.



**DISPOSAL OF OLD ELECTRICAL & ELECTRONIC EQUIPMENT.**

This symbol on the product or its packaging indicates that this product shall not be treated as household waste. Instead, it shall be handed over to the applicable collection point for the recycling of electrical and electronic equipment, such as for example:

- sales points, in case you buy a new and similar product
- local collection points (waste collection center, local recycling center, etc...)

By ensuring this product is disposed of correctly, you will help prevent potential negative consequence for the environment and human health, which could otherwise be caused by inappropriate waste handling of this product. The recycling of materials will help to conserve natural resources. For more detailed information about recycling of this product, please contact your local city office, your household waste disposal service or the shop where you purchased the product.

**Attention:** in some countries of the European Union, the product is not included in the field of application of the National Law that applies the European Directive 2002/96/EC and therefore these countries have no obligation to carry out a separate collection at the "end of life" of the product.

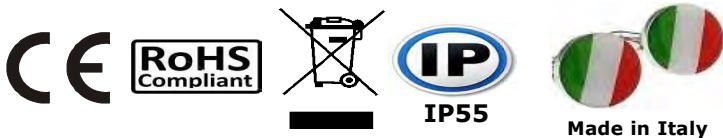

**Sensor SGI621** *Lo styling è della b & b design*

<p>Purchase date : .....</p> <p>Serial Number : .....</p> <p><b>The Beinat S.r.l.</b> following the targhet to improve its products, reserves the right to modify the technical features, aesthetic and functional any time without prior notice.</p>	<p>Stamp and signature of the dealer</p>
---	--

**BEINAT S.r.l.**  
Via Fatebenefratelli 122/C 10077, S. Maurizio C/se (TO) - ITALY  
Tel. 011.921.04.84 - Fax 011.921.14.77  
[http:// www.beinat.com](http://www.beinat.com)

**Business** - [info@beinat.com](mailto:info@beinat.com)  
**Help Desk** - [laboratorio@beinat.com](mailto:laboratorio@beinat.com)